

Indice Sunscreen

SB160 CV -F MOTORE:

TAV.410.12 Scheda generale

TAV.410.13 Testate a forcella in fusione di alluminio, cassonetto in alluminio pressopiegato, guide in cavo inox $\varnothing 8\text{mm}$, tessuto filtrante

SB160 CV-F MOTORE
SCHEMA GENERALE

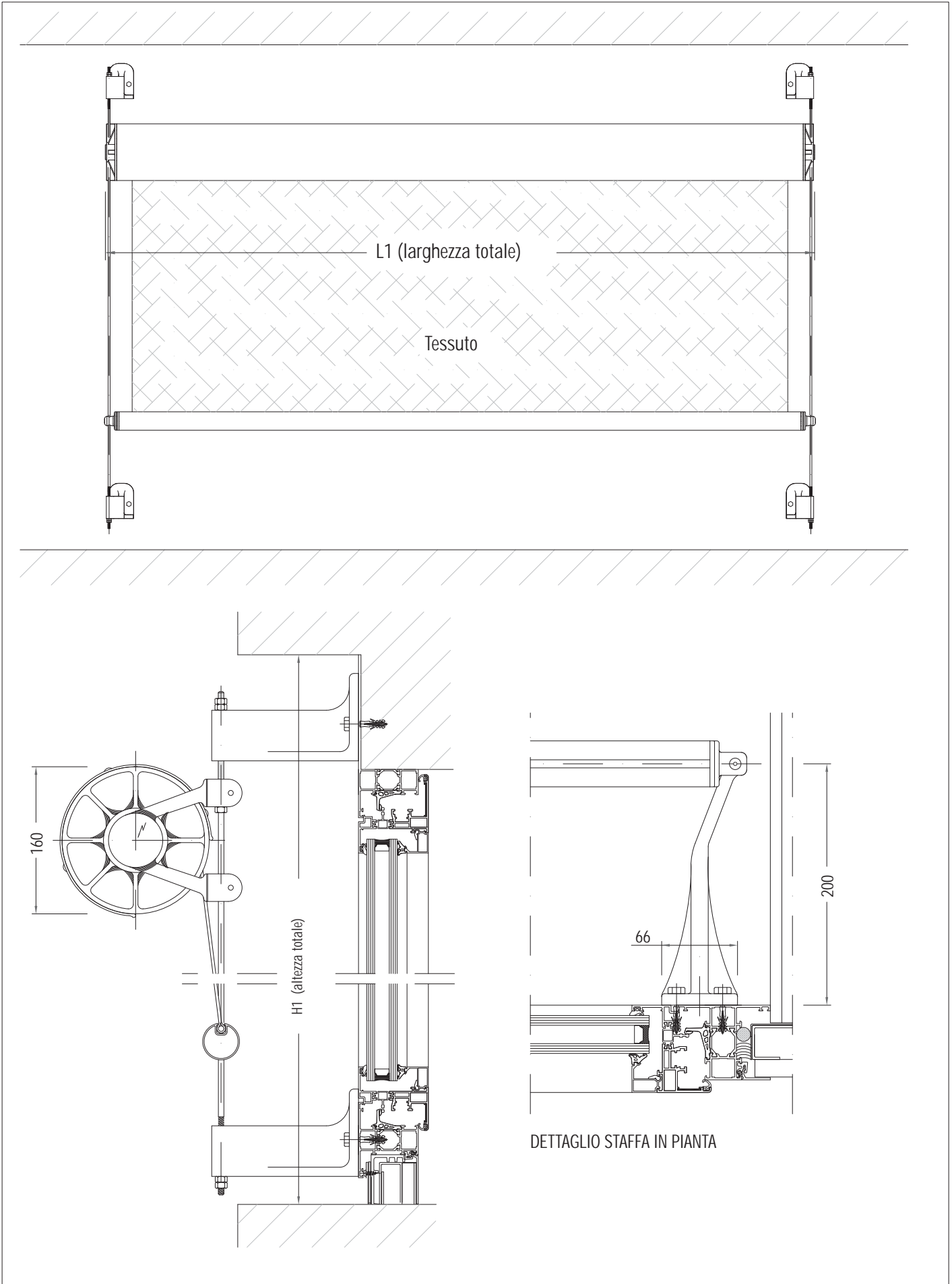

SB160 CV-F MOTORE

230 V 50 Hz 10 A
(Cavo alimentazione n° 4x0,75 mm²)

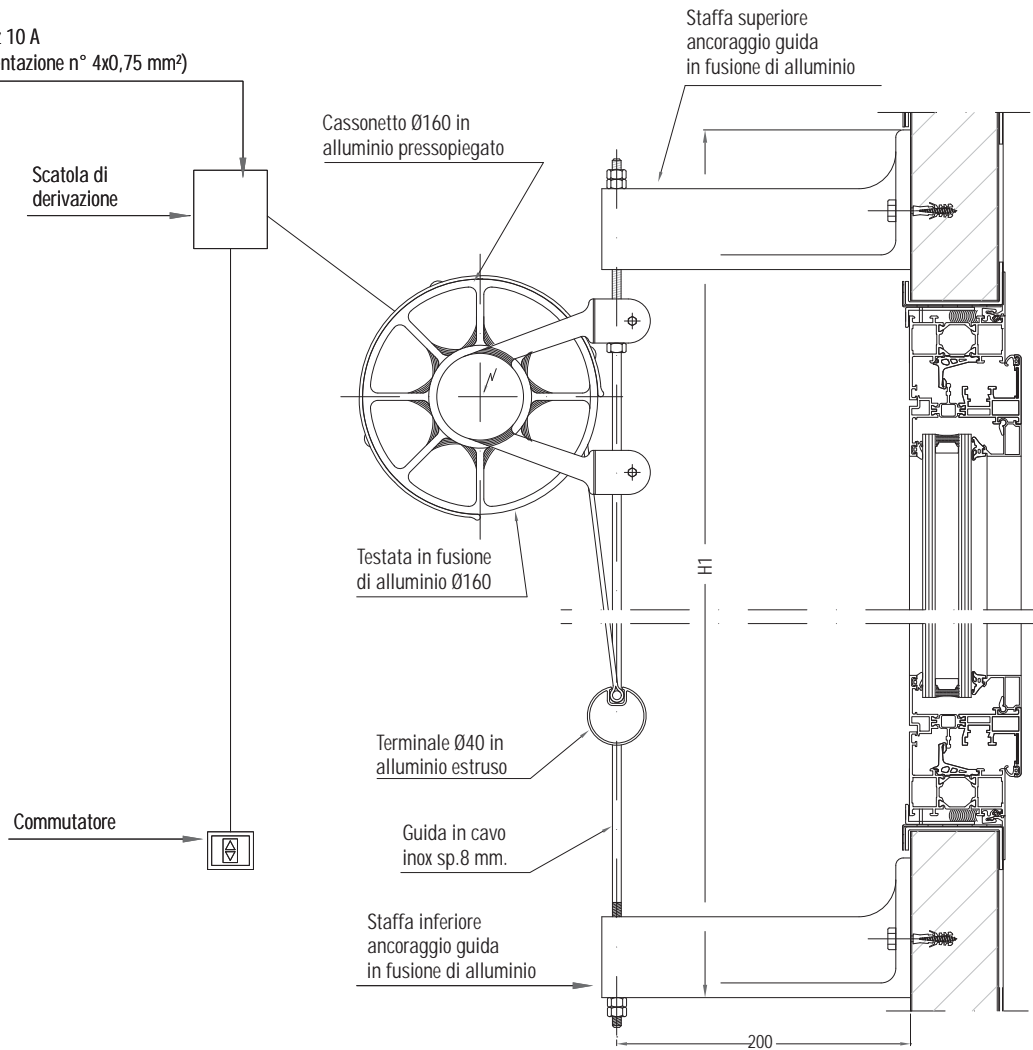

DIMENSIONI:

L1		H1		TOT. mq
min.	max	min.	max	
700	3200	400	4000	7

